

OWNER'S INSTRUCTION MANUAL



CALLER ID TYPE II MULTI-FEATURE TELEPHONE MODEL 2700



Thank You
for Purchasing the
2700 Caller ID Type II
Multi-Feature Telephone

We want you to know all about your new Telephone, how to install it, the features it provides, and the services you can expect from its use. We have included this information in your Owner's Instruction Manual.

**PLEASE READ BEFORE INSTALLING
AND USING YOUR NEW TELEPHONE EQUIPMENT.**

Contents

IMPORTANT SAFETY INSTRUCTIONS	5
Telephone Part Identification	6
INSTALLATION.....	7
ANSWERING MACHINE	7
UNIT SETUP	8
TELEPHONE FEATURES	9
DIALING.....	9
RECEIVING A PHONE CALL	9
PLACING A PHONE CALL.....	9
PREDIAL.....	9
SPEAKER BUTTON	9
DURATION COUNTER.....	9
MUTE BUTTON	9
AUTOMATIC MEMORY	10
Storing A Number	10
Dialing A Number.....	10
VOLUME BUTTON	10
REDIAL BUTTON	10
PAUSE BUTTON	10
HOLD BUTTON	10
FLASH BUTTON.....	10
HEADSET BUTTON	10
DATA PORT	10
CONTRAST BUTTON.....	11
RELEASE BUTTON.....	11
VOICEMAIL BUTTON.....	11
DIRECTORY BUTTON.....	11
MESSAGE LIGHT.....	11
MESSAGE WAITING	11
KEY TONE	11

CALLER ID FEATURES 11

CALL WAITING DISPLAY 11

RECEIVING CALLS..... 11

REVIEWING CALLS..... 12

DELETING CALLS 12

CALLBACK..... 12

7-10-11 BUTTON 12

MESSAGE ERROR..... 12

NO DATA SENT 12

PRIVATE CALLS 12

UNKNOWN CALLS 13

USING THE DIRECTORY 13

STORING ENTRIES..... 13

FINDING ITEMS..... 13

DIALING DIRECTORY NUMBERS..... 13

DELETING ITEMS 13

TELEPHONE SERVICE PROBLEMS 14

MAINTENANCE INFORMATION 14

TELEPHONE REPAIR 15

FCC Information 15

Limited Warranty 16

IMPORTANT SAFETY INSTRUCTIONS

Always follow basic safety precautions when using your telephone equipment to reduce the risk of fire, electrical shock, and injury.

1. **Read and understand all instructions** in the Owner's Instruction Manual.
2. **Read all warnings** and follow all instructions marked on the product.
3. **Unplug this product from the wall outlet before cleaning.** Use a damp cloth for cleaning. Do not use liquid or aerosol cleaners.
4. **Do not use the telephone near water.** For example, do not use near a bathtub, wash bowl, kitchen sink, laundry tub, swimming pool, or in a wet basement.
5. **Do not place this product on an unstable cart or stand.** The product may fall causing serious damage to the product.
6. **Use only the type power source indicated on the label.** If you are not sure of the type power supply to your home, consult your dealer or local power company.
7. **Do not place any objects on the telephone line cord.** Do not locate the telephone where the line cord will be walked on.
8. **Do not block or cover ventilation slots and openings** in the bottom of the telephone. The openings should never be blocked by placing the telephone on a bed, sofa, rug, or other similar surfaces. The telephone should never be placed near or over a radiator or heat register. The telephone should never be placed in a built-in installation unless proper ventilation is provided.
9. **Never spill liquid on the telephone or push objects of any kind through ventilation slots.** Liquid or objects may touch dangerous voltage points or short out parts that could result in a risk of fire or electrical shock.
10. **Do not disassemble this product.** Opening or removing covers may expose you to dangerous voltages or other risks. Incorrect reassembly can cause electrical shock when the product is subsequently used.
11. **Do not overload outlets and extension cords.** Some telephones require AC power from an outlet. Overloading the outlets can result in the risk of fire or electric shock.
12. **Avoid using a telephone during a local thunderstorm.** There may be a remote risk of electrical shock from lightning. Fuse (F1) is rated at 0.75A/250V Time delay.
13. **Do not use a telephone to report a gas leak in the vicinity of the leak.**
14. **Unplug the telephone from the wall outlet and refer servicing to qualified service personnel** under the following conditions:
 - When the line cord is frayed or plugs damaged.
 - If liquid has been spilled into the telephone.
 - If the telephone has been exposed to rain or water.
 - If the telephone does not operate properly by following the operating instructions. (Adjust only those controls covered by the operating instructions. Improper adjustment of other controls may result in damage and will often require extensive work by a qualified technician to restore the product to normal operation.)
 - If the telephone has been dropped or the housing damaged.
 - If the telephone exhibits distinct change in performance.

CAUTION - Always disconnect all telephone lines from the wall outlet before servicing or disassembling this equipment.

SAVE THESE INSTRUCTIONS

Telephone Part Identification

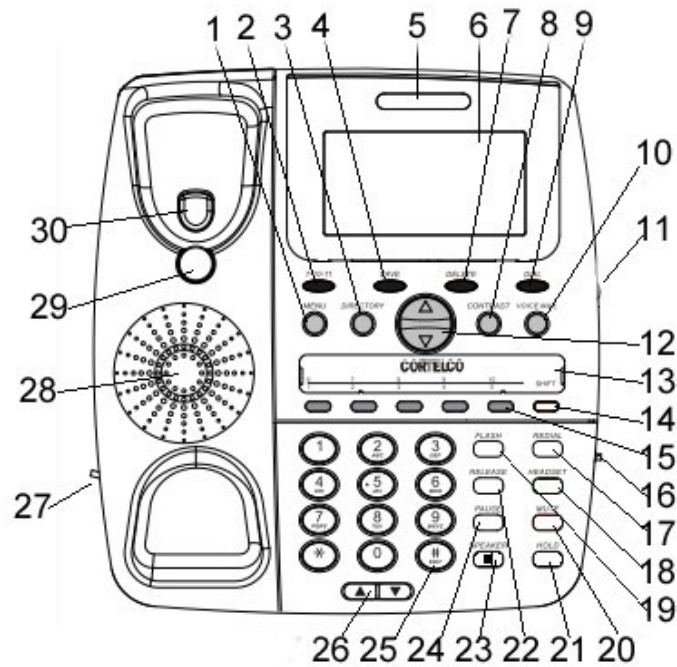

1	Menu Button	16	RJ-9 Headset Jack
2	7-10-11 Button	17	Redial Button
3	Directory Button	18	Headset Button
4	Save Button	19	Flash Button
5	Message Lamp	20	Mute Button
6	Multi-Angle LCD	21	Hold Button
7	Delete Button	22	Release Button
8	Contrast Button	23	Speaker Button
9	Dial Button	24	Pause Button
10	Voice Mail Button	25	Edit Button
11	2.5 mm Headset Jack	26	Volume Up/Down Button
12	Review Up/Down Button	27	Handset Jack
13	Directory/Logo Strip	28	Speaker
14	Shift Button	29	Handset Hook
15	Memory Buttons	30	Hookswitch

INSTALLATION

DESK MOUNT

1. Select the desired viewing angle and install the desk stand. The desk stand can be installed in two positions to give a choice of viewing angle.
2. Connect the power adapter. The power adapter connects to the jack marked DC 9V on the bottom of the phone. Plug the large part of the adapter into the wall outlet. Use only a 9V DC, 200mA or 300mA, center positive Class 2 adapter.
3. Connect the line cord. The line cord connects to the jack marked LINE on the bottom of the phone..
4. Plug the coiled cord into the handset jack, and then plug the other end of the cord into the base.
5. Place the handset on the base.

WALL MOUNT

1. Remove the desk stand. The unit will then mount directly on a standard wall telephone jack.
2. Connect the power adapter and the line cord. See Steps 2 and 3 above.
3. Rotate the handset hook into the wall mount position.
4. Plug the coiled cord into the handset, and then plug the other end of the cord into the base.
5. Place the handset on the base.

ANSWERING MACHINE

1. Connect the LINE jack of the answering machine to the wall telephone jack.
2. Connect the LINE jack of the model 2700 phone unit to the PHONE jack of the answering machine.
3. Set the answering machine to answer after 2 or more rings.

MESSAGE WAITING LAMP

If your phone is installed behind a Message Waiting enabled PBX, you will need to set the M/W switch in order to receive Message Waiting indication.

1. Locate the switch on the bottom of the telephone.
2. For 90V PBX Message Waiting Indication, move the switch to the position marked "90V". For 24V PBX Message Waiting Indication, move the switch to the position marked "24V". If connecting directly to telephone lines, move the switch to the center "OFF" position.

Warning: Setting this switch in a position other than OFF can cause this phone to function incorrectly. When enabled, this feature is for PBX systems, and not meant for direct Central Office (CO) interface. If connecting to CO telephone lines, make sure this switch is set to OFF.

Please note that the settings of your message waiting service such as the PIN are not controlled by the 2700. For information about your PIN or to make changes to your message waiting service, contact your telephone service provider for instructions.

UNIT SETUP

FACTORY PRESETS

The following table shows the default factory settings:

Language	English
Stutter Tone	Yes
Area Code	No Setting
LDS Code	1
Access Code	No Setting
Time and Date	No Setting
Flash Time	600 mS
Ringer Cadence	3
Ringer Volume	5
Voicemail Number	No Setting
Number of 3 Sec Pauses	No Setting
Voicemail Password	No Setting
Hold Mode	NORMAL
Release Mode	NEW CALL
SDT Time	1700 mS
ENABLE KEY TONE	NO

*Note: After the unit has been completely configured for the first time, use **MENU** to review or reprogram the features.*

After the adapter is connected, the display will show as indicated below for setting.

1. [**SELECT LANGUAGE**] appears on the display. Press **REVIEW UP** to select the language. ENG - English, ESP - Spanish, FRE - French, and then press **MENU** to confirm the selection.
2. When [**STUTTER TONE**] appears, the default setting is "YES". To toggle stutter tone, press 1 for Yes or 2 for No. Press **MENU** to confirm selection.
3. When [**ENTER AREA CODE**] appears, enter the desired area code using the keypad. Use **REVIEW UP** and **REVIEW DOWN** to skip a digit. Press **MENU** to confirm area code. Follow the same procedure for both area code settings. To leave an area code blank, press **MENU** without entering digits.
4. When [**SET LDS CODE**] appears, enter the desired LDS code using the keypad. This is the code which is dialed for a Long Distance Call. In North America, this code is "1." Press **MENU** to confirm the selection.
5. When [**SET ACCESS CODE**] appears, enter the desired Access code using the keypad. This is the code that is dialed to access an outside line. Press **MENU** to confirm the selection.
6. When [**EDIT TIME & DATE**] appears, enter the time using the keypad. If the time is AM, press **REVIEW UP** since this is the default value. If the time is PM, press **REVIEW DOWN** and then press **REVIEW UP**. Press **MENU** to confirm the settings. Example: To enter 8:35 AM, enter 0835 and then press **REVIEW UP** to skip to the date because the time is AM by default.
7. When [**FLASH TIMER (MS)**] appears, press **REVIEW UP** to toggle between 600ms, 100 ms, and 300ms. After selecting the desired flash time, press **MENU** to confirm selection.
8. When [**RINGER CADENCE**] appears, the default setting is 3. To alter this setting, press **REVIEW UP**. There are 10 ringer cadences and each one will be played as you scroll through them. After the desired ringer cadence is displayed, press **MENU** to confirm selection.
9. When [**RINGER VOLUME**] appears, the default setting is 5. To alter the ringer volume, press **REVIEW UP**. There are 7 ringer volume levels and each one will be played as you scroll through them. To turn the ringer off, select [OFF] in the Menu. After the desired ringer volume level is displayed, press **MENU** to confirm selection.
10. When [**VOICEMAIL NUMBER**] appears, enter the voicemail number (maximum of 18 digits) using the keypad. To delete a number or digit, press **REVIEW DOWN** to erase the number(s). After the desired number has been entered, press **MENU** to confirm selection.
11. When [**#3 SEC PAUSES**] appears, enter the desired number of pauses using the keypad. After the desired setting has been entered, press **MENU** to confirm selection.
12. When [**VM PASSWORD**] appears, enter the desired password using the keypad (maximum of 5 digits). To delete a number or digit, press **REVIEW DOWN** to erase the number(s). After the desired number has been entered, press **MENU** to confirm selection.

13. When *[HOLD MODE]* appears on the display. Press **REVIEW UP** to select either NORMAL or PBX. In NORMAL mode, the HOLD button activates a local hold function. This can be released at any parallel phone. In PBX mode, the HOLD button dials a code which places a PBX line on hold. If you select PBX mode, see Step 15 to program the code.
14. When *[RELEASE MODE]* appears on the display. Press **REVIEW UP** to select either NEWCALL or HANGUP. In NEWCALL mode, the RELEASE button provides a 1.5 second line break. This will ensure that the line is clear and a new call can be dialed. In HANGUP mode, the RELEASE button drops the line and a new connection is not made. This is primarily intended for programming into speed dial locations.
15. When *[SDT TIME]* appears on the display, press **REVIEW UP** to change Stutter Dial Tone timing. Please note that the default setting of 1700 mSec is correct for most applications.
16. When *[ENABLE KEY TONE]* appears, use 1 to activate this feature or 2 to deactivate it. When this feature is activated, a tone will sound in the receiver or the speaker when a key is pressed.
17. This only applies if you have selected PBX HOLD mode.
 - a. Press **SAVE**. The display shows *[SAVE TO ?]*
 - b. Press **HOLD**. The display shows *[ENTER NUMBER >]*
 - c. Dial the code using the keypad.
 - d. Press **SAVE**.

TELEPHONE FEATURES

DIALING

The 2700 is only capable of DTMF dialing. It is not capable of pulse dialing.

RECEIVING A PHONE CALL

1. When the phone rings, lift the handset or press **SPEAKER** to begin your conversation.
2. To change the Ringer Volume, refer to the "Factory Presets" section.

PLACING A PHONE CALL

1. Lift the handset or press the **SPEAKER** button and wait for a dial tone.
2. Dial the telephone number you wish to call. The number will appear on the display window.

PREDIAL

1. While the handset is on hook, enter the desired telephone number using the key pad. The number will appear in the display. To delete a digit or the entire number, press **REVIEW DOWN**.
2. To dial the displayed number, lift the handset, press **SPEAKER** or **DIAL**.

SPEAKER BUTTON

NOTE: Power Adapter must be used to ensure proper function

1. Receiving Incoming Calls

- a. When the phone rings, press and release **SPEAKER** and speak normally into the built-in microphone from a distance of 5-6 inches.
- b. You can adjust the volume of the caller's voice by pressing the Volume Button on the base of the telephone.
- c. After the conversation has finished, press and release **SPEAKER** to hang up.

2. Making A Call

- a. Press and release **SPEAKER**.
- b. When you hear a dial tone, dial the number or press the auto memory button. The number will appear on the display window.
- c. When your party answers, adjust the volume of the conversation by pressing the Volume Button on the base of the telephone.
- d. After the conversation has finished, press and release **SPEAKER** to hang up.

Note:

1. If you wish to switch from speakerphone to handset, simply lift the handset.
2. If you wish to switch from handset to speakerphone, press and release **SPEAKER** and then hang up the handset.

DURATION COUNTER

A built-in counter will start counting 6 seconds after you lift the handset or 6 seconds after you dial a telephone number.

MUTE BUTTON

Press **MUTE** to speak without the person on the phone hearing your conversation. The **MUTE** Indicator will light up and remain lighted until you resume your conversation. Also, "MIC MUTED" will show in the display. To resume the conversation, press **MUTE**. The **MUTE** indicator will go out and your call can continue.

AUTOMATIC MEMORY

Storing A Number

1. Press **SAVE**, [*SAVE TO?*] appears on the display window.
2. Press the desired memory location. (M1-M5 or SHIFT M1-M5)
3. [*ENTER NUMBER>*] appears on the display.
4. Enter the desired number using the keypad (maximum of 24 digits). Press **SAVE** to confirm.
5. [*ENTER NAME>*] will appear. Type the name (16 characters max.) using the keypad. Use **REVIEW UP** to add a space. Use **REVIEW DOWN** to delete a character. Press **SAVE** again.
6. [*SET VIP RING*] will appear. Use **REVIEW UP** and **REVIEW DOWN** to select the desired ring cadence. Press **SAVE** again.
7. [*MEMORY STORING*] will show briefly.

Dialing A Number

1. Press the desired memory location (M1-M5 or SHIFT M1-M5)
2. The number will be displayed.
3. To dial the number, lift the handset, press **SPEAKER** or press **DIAL**.

VOLUME BUTTON

A built-in amplifier feature allows you to change the listening volume in the receiver of the handset when speaking with your party. Press **VOLUME UP** or **VOLUME DOWN** to achieve different levels. The volume remains the same between calls. It does not return to a nominal level.

REDIAL BUTTON

1. To redial one of the last 10 numbers dialed, press **REDIAL**. The display will show the last number dialed. To scroll through the last 10 numbers, press **REVIEW UP** or **REVIEW DOWN**.
2. After the desired number is selected, dial the number by pressing **REDIAL** again, lifting the handset, pressing **SPEAKER** or pressing **DIAL**.
3. The selected number (32 digits maximum) will be redialed.

PAUSE BUTTON

PAUSE allows you to insert a 3.6-second pause in the dialing sequence. This is particularly useful if you are connected to a PABX system where you must dial an access code (usually the number 9) to obtain an outside line.

1. Press **PAUSE** and release at any point in the dialing sequence where a pause is desired.
2. **PAUSE** can be pressed more than once to create a longer pause.

HOLD BUTTON

1. NORMAL MODE

- a. Press **HOLD** and hang up the handset. **HOLD** will light up and remain lighted until you resume your conversation.
- b. To resume your conversation, lift the handset or that of any extension phone on the same line or press and release **SPEAKER**. The HOLD indicator will go out and your call can continue.

2. PBX MODE

Press **HOLD**. The phone will dial out the code. Depending on the PBX, it may now be necessary to hang up the handset. Note that **HOLD** will not light in this mode.

FLASH BUTTON

This telephone provides a line break signal for accessing PABX service or for use of Call Waiting from your local telephone company. If you have Call Waiting service, you can use the Call Waiting function per the following instructions.

1. While having a conversation, another party calls and you hear a tone.
2. Press **FLASH** once and release. The first conversation is placed on hold and the second call can be answered.
3. Press **FLASH** again and release. You may speak to the first caller again and the second call is placed on hold.

HEADSET BUTTON

This telephone will accept either a 2.5 mm cell phone-style headset or an RJ type headset. Use **HEADSET** to connect and disconnect from calls.

DATA PORT

This is a connection which is in parallel with the telephone line. It allows the connection of a device such as a modem, caller ID, or an answering machine. This connection is located on the bottom of the phone and is marked DATA.

CONTRAST BUTTON

Contrast can be altered whether on hook or off hook by pressing **CONTRAST**. There are 3 contrast levels.

RELEASE BUTTON

To end a conversation, press **RELEASE** once. There are two modes for **RELEASE**.

1. NEW CALL

In NEW CALL mode, the phone goes on-hook for 1.5 seconds and then goes off hook again. This allows you to make another call.

2. HANG-UP

In HANG UP mode, the phone does not come back off hook. This allows you to program a RELEASE into a speed dial location.

VOICEMAIL BUTTON

Press **VOICEMAIL** to dial the voicemail access number and pin. See *Unit Setup* section for details.

DIRECTORY BUTTON

DIRECTORY is used to store the name and number of up to 99 of your most frequently dialed contacts. The names are sorted alphabetically.

MESSAGE LIGHT

If you have a voice mail service with your telephone company, the large indicator at the top of the display will flash red to alert you that you have new messages.

The **MESSAGE** indicator also monitors the unit's situation. When the phone is in use, the **MESSAGE** indicator will be on continuously.

MESSAGE WAITING

This unit's MESSAGE WAITING DETECTION is for both FSK and Stutter Dial Tone (SDT) systems.

1. FSK

The **MESSAGE** indicator will flash and [MESSAGE WAITING] will appear on the display for 20 seconds when a message waiting signal is received from the Central Office.

2. SDT

This unit will check your line for a stutter dial tone every time you hang up or each time a call goes unanswered. The **MESSAGE** indicator will flash if a stutter dial tone is detected. There may be some delay in lighting the **MESSAGE** indicator. This delay is due to regulatory matters and does not indicate a problem with the unit.

This unit may not be activated or deactivated under certain conditions. For example, when you retrieve messages from an outside phone (not your own telephone number), the **MESSAGE** indicator may not be canceled when you return home. If you experience this situation, pick up the handset and hang up. The **MESSAGE** indicator will cancel.

KEY TONE

If this feature is activated, a tone will sound in the receiver or speaker when a key other than the number keys is pressed.

CALLER ID FEATURES

CALL WAITING DISPLAY

Call-waiting service alerts you to a new call by playing a tone while you are on a call. Call Waiting Caller ID not only tells you there is another call waiting, but lets you know who the caller is before the call is answered. The name and number of the incoming call will be shown on the unit's display. This information will remain displayed for 16 seconds. In addition to this, the CALL WAITING symbol (CW) will flash.

RECEIVING CALLS

1. When the telephone is not in use and a new call is received, the display will show the *NEW* symbol, the phone number, the caller's name, and the call time for 20 seconds. The *REPEAT* symbol will appear if the call has come in more than once.
2. After 20 seconds with no activity, the display will default to the Stand-By screen until another call is received or a button is pressed.

REVIEWING CALLS

1. When in Standby Mode, press **REVIEW UP** or **REVIEW DOWN** to see the stored calls. This unit stores up to 99 calls.
2. The *NEW* symbol will be removed from each call after it is reviewed.
3. The reviewed number can be stored into any of the auto memory buttons:
 - a. With the number displayed, press **SAVE**.
 - b. [SAVE TO ?] will appear. Press M1-M5 or SHIFT M1-M5. Press **SAVE** again.
 - c. The caller's name will appear. Press **SAVE** again.
 - d. [SET VIP RING] will appear. Use **REVIEW UP** and **REVIEW DOWN** to select the desired ring cadence. Press **SAVE** again.
4. When the end of the call records is reached, the display will show [-END OF LIST-].

DELETING CALLS

Individual call

1. Display the desired record by pressing **REVIEW UP** or **REVIEW DOWN**
2. Press **DELETE**. The display will show [DELETE? 1:YES 2:NO].
3. Press 1 to confirm the deletion.

All calls

1. Display the desired record by pressing **REVIEW UP** or **REVIEW DOWN**
2. Press and hold **DELETE** for more than 3 seconds. The display will show [DELETE ALL 1:YES 2:NO].
3. Press 1 to confirm the deletion.

CALLBACK

When reviewing received calls, there are two ways to dial the telephone numbers shown on the display by pressing **DIAL**.

1. If you have reviewed the calls with the telephone handset on hook, press **DIAL**. The HANDSET symbol in the display will come on, and the number you have selected will be dialed automatically via the speakerphone.
2. If you have already picked up the handset or activated the speakerphone, you may select the number to be dialed by reviewing the stored calls. After locating the desired number, press **DIAL**. The displayed number will be dialed automatically.

7-10-11 BUTTON

7-10-11 allows you to change the format of the displayed number. These are the available formats:

7-digit	7-digit telephone number.
10-digit	3-digit area code + 7-digit telephone number.
11-digit	long distance code 1 + 3-digit area code + 7digit telephone number.

If a local call, and its 7-digit number is displayed:

- Pressing **7-10-11** once will change it to a 10-digit format (your area code + 7-digit number).
- Pressing **7-10-11** twice will change it to an 11-digit number (1 + your area code + 7-digit telephone number).
- Pressing **7-10-11** three times will go back to the original 7-digit telephone number.

If a long distance call, and its 10-digit number is displayed,

- Pressing **7-10-11** once will remove the 3-digit area code and change it to a digit number.
- Pressing **7-10-11** twice will go back to the original 10-digit number.
- Pressing **7-10-11** three times will add the LDS code to the number. (1+ 3-digit area code + 7-digit telephone number).

When the desired format of the telephone number is reached, press **DIAL** to dial the displayed number.

MESSAGE ERROR

The display shows [-MESSAGE ERROR-] if your unit receives a call that has an error in the transmission or reception.

NO DATA SENT

The display shows [-NO DATA SENT-] if there is no caller ID (CID) number sent from the telephone company.

PRIVATE CALLS

- If the caller has exercised the option to block his number from being sent, [PRIVATE NUMBER] and his name will alternately display on the screen.
- If the caller has exercised the option to block his name from being sent, [PRIVATE NAME] and his telephone number will be displayed on the screen.

- If the caller has exercised the option to block his name and number from being sent, [*PRIVATE CALLER*] will be displayed on the screen.

UNKNOWN CALLS

- When the telephone company is unable to provide the caller's telephone number, [*UNKNOWN CALLER*] and his name will alternately display on the screen.
- When the telephone company is unable to provide the caller's name, [*UNKNOWN NAME*] and his telephone number will be displayed on the screen.
- When the telephone company is unable to provide the caller's name and number, [*UNKNOWN CALLER*] will be displayed on the screen.

USING THE DIRECTORY

This unit stores the numbers of up to 99 of your business associates, clients, contacts, and friends in your directory. Names are sorted alphabetically starting with the first character. (If you want your Directory sorted by the last name, enter the last name first.)

STORING ENTRIES

Press **SAVE** to store a number in the Directory. After pressing **SAVE**, the display will show [Save To?]. Press **DIRECTORY**. [Enter Number>] will appear in the display. Enter the desired number using the keypad. (max 24 digits). Press **SAVE** to confirm. [Enter Name] will appear. Type the name using the keypad. Press **SAVE** again to confirm all settings. [Number Stored] will show briefly.

Note: For Example, if A is the desired letter, press the #2 button once and A will appear on the display. If B is the desired letter, press the #2 button twice and B will appear on the display. Pressing the #2 button three times will select the letter C. If an incorrect letter is accidentally selected, press the down review arrow and start over. All letters are upper case. To enter a space when storing a name or number, press the up review arrow. Use the "#" key to edit entries.

FINDING ITEMS

Press **DIRECTORY** to enter the Directory Review Mode. The first entry in the Directory is displayed. The Down and Up Review Arrows may be used to scroll through the directory. To leave the directory at any time, press **DIRECTORY**. To search for a directory entry, press **DIRECTORY**. Then, using the keypad, type the desired name.

DIALING DIRECTORY NUMBERS

Find the number you want to dial in the Directory List. (Telephone can be on or off hook) When the number shows on the display, press **DIAL** to start dialing.

DELETING ITEMS

Deleting Individual Entries

Enter the directory and select the individual entry. To delete an individual entry, press **DELETE** once and then press 1 to confirm or 2 to cancel. The display will be erased and the remaining items will be re-sorted.

Deleting All Entries

Enter the directory. To delete all entries, press and hold **DELETE** button. [DELETE ALL] will appear in the display, select (1) for YES or (2) for NO. [NO RECORDS] appears in the display confirming there are no directory entries in memory.

TELEPHONE SERVICE PROBLEMS

If you have any problems with your telephone service, determine if the problem is with your unit or the telephone company lines BEFORE CALLING THE TELEPHONE COMPANY. Be aware that the telephone company may charge you for a service call if the problem is caused by your telephone.

PHONE DOES NOT RING

1. Line cord is disconnected at telephone outlet or at telephone.
2. Phone is **OFF HOOK**. Make certain the hookswitch is depressed when the handset is in the cradle.
3. **SPEAKERPHONE** indicator is on. Turn off speakerphone.

NO DIAL TONE

Wire is disconnected at telephone or at wall jack. Test the telephone in a different wall jack. If it works, the first jack may be defective.

REDIAL BUTTON DOES NOT FUNCTION

The telephone may have been momentarily disconnected from the telephone jack.

BLANK SCREEN

1. Check if the adapter is connected properly.
2. Press the Contrast button to see if contrast level is set correctly.

CALLERS ARE NOT DISPLAYED ON THE SCREEN

1. Verify that you have subscribed to the appropriate service (Caller ID and Call Waiting Caller ID) from your telephone company. If you only subscribed to Caller ID service the unit will not display call waiting caller ID information.
2. Check if your answering machine is set to answer before 2 rings.

NO CALLER INFORMATION IS DISPLAYED WHEN HEARING THE CALL WAITING BEEP

Verify that you have subscribed to Call Waiting Caller ID service.

MESSAGE ERROR HAPPENS FREQUENTLY

Caller information was not transmitted properly. Check with your telephone company to see if there is a problem with your phone line.

Since call records will be retained even with the power adapter disconnected, please disconnect all the telephone cords and power adapter; and then reinstall the telephone step by step per this instruction manual before asking for service.

MAINTENANCE INFORMATION

Treat your telephone equipment with care for trouble-free performance. Avoid dropping the handset. Carefully place the handset on-hook after use.

Avoid putting near heating appliances and devices that generate electrical noise (for example, motors and florescent lamps).

Clean your telephone equipment with a damp cloth. Stains may be removed with a mild soap. Do not use liquid or aerosol detergents or cleaning agents.

Do not expose to direct sunlight or moisture

Retain the original package in case you need to ship it at a later date.

TELEPHONE REPAIR

DO NOT ATTEMPT TO REPAIR THIS PRODUCT YOURSELF. Telephones manufactured by CORTELCO must be returned to us for repair.

You can return your telephone to CORTELCO for repair or replacement in accordance with our LIMITED WARRANTY.

CORTELCO warrants **THIS PRODUCT** against defects in material and workmanship in accordance with our LIMITED WARRANTY. If your telephone is returned for repair, include a copy of your sales receipt containing the date-of-purchase. DO NOT INCLUDE THE ORIGINAL SALES RECEIPT.

If date-of-purchase is not included, the factory date printed on the label on the bottom of your telephone will be used as the date-of-purchase. The factory date allows six months for distribution and sale of this product.

If you return your telephone for repair, the warranty period is not extended. The original date-of-purchase continues to apply to your warranty.

OUT-OF-WARRANTY REPAIR We will repair this product for a nominal fee after the LIMITED WARRANTY has expired if you send it to us in a complete and undamaged condition. The repaired unit will be shipped to you C.O.D., freight collect.

RETURN-FOR-REPAIR PACKAGING If you are returning a unit to us for repair, package it carefully, preferably in the original carton. Be sure to include your return address, a copy of the sales receipt showing date-of-purchase, and a note describing the problem you have with your Telephone. Shipping must be prepaid. If the telephone is in warranty, it will be repaired or replaced, at our option, at no cost to you, and it will be returned shipping prepaid.

Ship your telephone (shipping prepaid) to:

CORTELCO
REPAIR CENTER
1703 SAWYER ROAD
CORINTH, MS 38834

FCC Information

Part 68 is a Federal regulation which requires equipment to be tested and registered with the FCC prior to its connection to the network. This equipment complies with Part 68 of FCC rules. On the bottom of the telephone is a label that contains, among other information, the FCC Registration Number and the Ringer Equivalence Number (REN) for this equipment. You must, upon request, provide this information to your telephone company.

The **Ringer Equivalence Number(REN)**, which is used to determine the number of devices you may connect to your phone line, indicates the amount of power that your telephone draws from the telephone company line during ringing. If you have more than one telephone (or other terminal device) connected to the telephone company line, you should total the RENs, and be sure that the total is not more than five. Your telephones may not ring if the total is more than five. Also, in some rural locations, your telephone may not ring if the REN total is more than three.

RESTRICTIONS You must not connect your telephone to coin-operated lines or party lines.

INSTALLATION This model telephone must be connected to the telephone company lines through a modular jack. The required USOC for the modular jack is RJ11C for desk mounting and RJ11W for wall mounting. The USOC number is printed on the label on the bottom of your telephone.

HEARING-AID COMPATIBILITY The handset on your telephone will work with magnetically-coupled hearing aids. You can use a hearing aid equipped with a T (Telephone) switch.

IN CASE OF TROUBLE If your telephone should cause problems on the telephone line, the telephone company can temporarily disconnect your service. The telephone company must then notify and allow you to correct the problem.

The telephone company may from time to time change its lines or equipment. They must notify you if planned changes will affect your telephone service, to allow you to take steps to prevent interruptions.

This telephone complies with Part 15 of the FCC Rules. In the unlikely event that interference occurs, move the telephone and/or radio, television, etc. to increase the separation distance.

Limited Warranty

If you purchased this product new in the U.S. or Puerto Rico, **CORTELCO** warrants it against defects in material and workmanship for a period of five (5) years from the date of original purchase. This warranty is in lieu of all other express warranties. During the warranty period, **CORTELCO** agrees to repair or, at its option, replace the defective product, or any part of it without charge for parts or labor. This is your exclusive remedy. This warranty does not cover damage resulting from accident, misuse, abuse, improper installation or operation, lack of reasonable care, the affixing of any attachment not provided by **CORTELCO** with the product and loss of parts. The warranty is voided in the event any unauthorized person alters or repairs the unit.

Telephone companies use different types of equipment and offer various types of services to customers. **CORTELCO does not warrant that this product is compatible with the type of equipment of any particular phone company or the services provided by it.**

CORTELCO DISCLAIMS ANY IMPLIED WARRANTY, INCLUDING THE WARRANTY OF MERCHANTABILITY AND THE WARRANTY OF FITNESS FOR A PARTICULAR PURPOSE, AS OF THE DATE FIVE YEARS FROM THE ORIGINAL PURCHASE OF THE PRODUCT. **CORTELCO** ASSUMES NO RESPONSIBILITY FOR ANY SPECIAL, INCIDENTAL OR CONSEQUENTIAL DAMAGES.

THIS WARRANTY GIVES YOU SPECIFIC LEGAL RIGHTS, AND YOU MAY HAVE OTHER RIGHTS WHICH VARY FROM STATE TO STATE. SOME STATES DO NOT ALLOW THE EXCLUSION OR LIMITATION OF SPECIAL, INCIDENTAL OR CONSEQUENTIAL DAMAGES OR LIMITATIONS ON HOW LONG AN IMPLIED WARRANTY LASTS, SO THE ABOVE EXCLUSION AND LIMITATION MAY NOT APPLY TO YOU.

If failure occurs and your telephone is in warranty, service shall be provided by returning it to **CORTELCO - Repair Center, 1703 Sawyer Road, Corinth, Mississippi 38834, shipping prepaid**. The product will be repaired or replaced if examination by us determines the product to be defective. Telephones received damaged as a result of shipping will require you to file a claim with the carrier.